

# Machines

For large and small companies





# Contents

Berry 538S/SP	3
Berry 539S/SP	4
Berry 574S	5
Berry 511S	6
Berry 521VG/Skin	7
Berry 911VG Jumbo	8
Berry 1705VG	9
Berry 1951VG	10-11
Berry 1752 & 1952VG	12-13



At Berry Superfos Packaging Solutions, we use our decades of experience in the packaging industry to deliver packaging systems for small and large companies. From small hand-operated machines, to fully automated, high-speed machines, each of our packaging systems includes:

- Recyclable PE-HD (Polyethylene High Density) plastic trays
- Sealing film
- Sealing machines
- Absorber pads
- Optional film sealing qualities for MAP (Modified Atmosphere Packaging), pasteurization, and more

Trays for our systems are made of recyclable Polyethylene High Density (PE-HD), one of the most environmentally friendly plastics in the food industry. They are suitable for MAP (modified atmosphere packaging), skin-packing, sterilization, pasteurization, cooling, and deep freezing. Trays can be heated using a microwave oven, hot air, or hot water, and have a temperature resistance ranging from 50°C to +121°C. Light weight trays can also be produced upon request.

Films that we offer include: general purpose sealing, peel-off, anti-fog, and skin-pack.



# Berry 538S/SP

## Manual sealing machine

Ideal for retail outlets that are looking for a cost effective and compact answer to their tray sealing needs, the 538S and 538SP provide an easy-to-use solution that doesn't compromise on quality. With both a space saving design and the versatility to handle a variety of tray depths, you can be sure that you provide your customer with a high-end product that is entirely suited to their needs. For those that require the added benefit of profile cutting, the 538SP comes fully equipped with a contour blade, offering an upmarket and professional finish to your trays.



### Tray System Advantages

A range of different tray sizes can be used. Manufactured in PE-HD, a recyclable plastic widely used in food industries, the trays and compatible types of sealing film provide an exceptionally robust and completely liquid-tight pack. If required, after removal of the sealing film, the pack can be re-heated in a microwave oven. The Berry Superfos Packaging Solutions pack gives a presentation of your product that is bound to impress and please your customers.

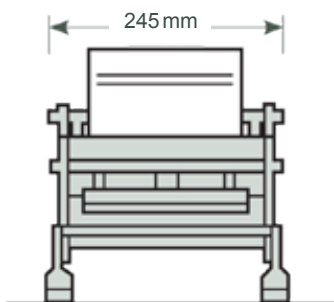

Technical data	538S/SP
Weight	8 kg (approx)
Voltage	350 W
Electric power	250 - 300 cycles per hour
Capacity	240 V, 50 Hz, single phase

Tray sizes available for these machines

538S	538SP
Group 1	Group 3*
Group 3	Group 4*
Group 4	

\*Available with peel-tab

# Berry 539S/SP

## Manual sealing machine

For organizations such as butcher's shops and fishmongers that require a larger tray capacity, the 539S and 539SP provide a robust packaging solution that is leak-proof, aesthetically pleasing, and built to handle a range of tray sizes with a simple tool change.

### Tray System Advantages

- Excellent presentation
- Tamper evident and drip free
- Fully recyclable material (PE-HD)
- Extraordinarily strong
- Stackable
- Capacities from 185 ml to 1.8 litre
- Suitable for freezing
- Film can be custom printed
- Available in various depths

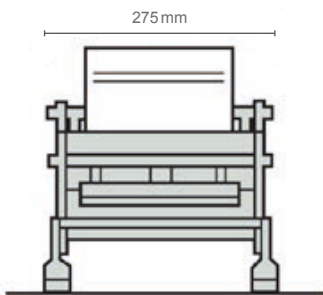

180mm

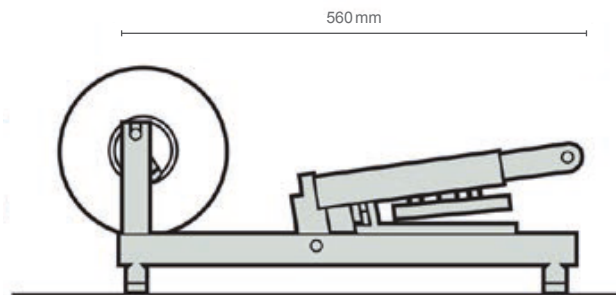

Tray sizes available for these machines

Technical data	539S/SP
Weight	10.5 kg (ca.)
Voltage	650 W
Electric power	250 - 300 cycles per hour
Capacity	240 V, 50 Hz, single phase

539S	539SP
Group 1/2	Group 4/1
Group 3/2	Group 6/1
Group 4/1	Group 8/1
Group 6/1	

# Berry 574S

## Semi automatic sealing machine

Reliability and speed are essential to growing your production business and that's exactly what the 574S can offer. Electrically operated and semi-automatic, this model is a stand-out solution for companies that seek an economic method of tray sealing in a range of depths and sizes. The user-friendly design achieves a presentable product in seconds.

### Options

- Film perforator
- Open-frame trolley with wheels
- Tray depth: 100 mm - 140 mm

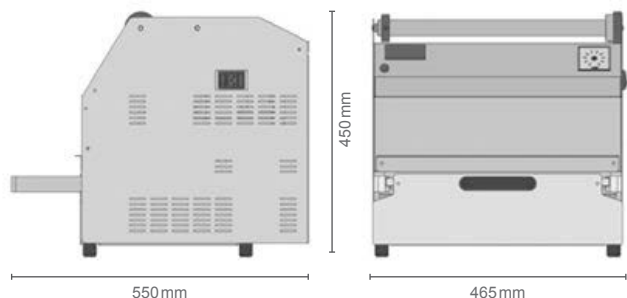

Number and max. tray dimensions processed per cycle



Technical data	574S
Overall dimensions	465 x 550 x 450 mm
Weight	40 kg
Max tray dimensions	380 x 280 mm
Max tray depth	100 mm (140)*
Max diameter of film roll	200 mm
Max width of film sealing	390 mm
Electrical supply	1 / N / PE 230V AC - 50 / 60 Hz
Power consumption	1800 W
Capacity	Up to 6 cycles /min.

\*Optional

# Berry 511S

## Semi automatic sealing machine





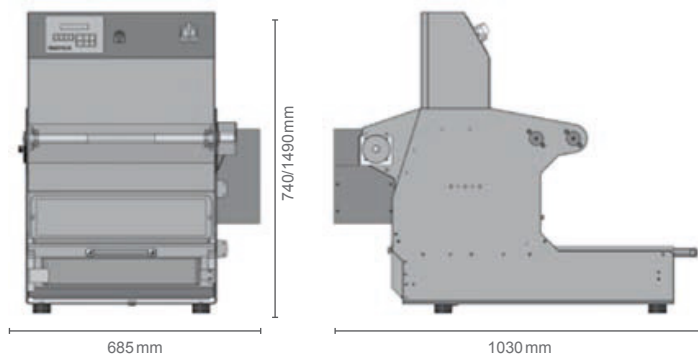

For those with a high-production setup that rely on their tray sealing machines all day every day, the semi-automatic 511S facilitates a fast turnaround and a robust end result. The versatile tool change accommodates an extensive range of tray sizes and depths, giving you the flexibility to cater for a wider range of products. The stand-alone design saves on sought-after space within your facility, whilst meeting a profound level of reliability that reduces downtime and maximises your company's efficiency.

### Options

- Photocell for printed film
- Tray lifting system
- Stand with wheels
- Film perforator



Number and max. tray dimensions processed per cycle

	Format 1.1 430 x 305 mm
	Format 1.2 430 x 142 mm
	Format 2.1 205 x 305 mm
	Format 3.1 130 x 305 mm
	Format 2.2 205 x 142 mm
	Format 4.1 95 x 305 mm
	Format 3.2 130 x 142 mm

Technical data	511S
External dimensions	685 x 1030 x H 740/1490 mm
Weight	100-125 kg
Max tray dimensions	430 x 305 mm
Max tray depth	150 mm
Max outside diameter of film roll	300 mm
Max width of film sealing	470 mm
Internal diameter film reel	70-76 mm
Electrical supply	1 / N / PE-230V AC 50 Hz
Power consumption	Max 4,2 KW
Capacity	2-6 cycles /min.
Compressed air	6 bar - 7NI / c

# Berry 521VG/Skin

## Semi automatic sealing machine

Minimal effect packaging is extremely popular with supermarkets and other retail outlets, who are constantly striving to achieve and maintain on-the-shelf presentability. To enhance the aesthetic appeal of your products, the 521 Skin model offers both skin and pro-skin packing capabilities, with a level of versatility that is second to none. This machine can also handle straight sealing, modified atmosphere, and vacuum packing with additional tooling, making it a perfect fit for companies that offer a range of products with individual packaging requirements.

### Options

- Photocell for printed film
- Filter for liquids and powders

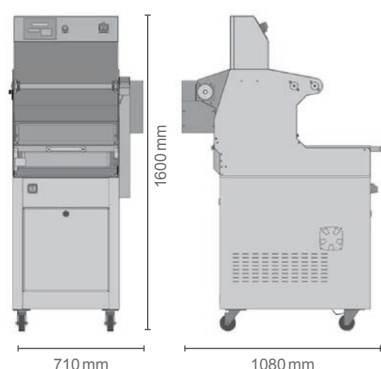

Technical data	511VG Skin
External dimensions	710 x 1080 x 1600 mm
Weight	Approx 215 kg
Max tray dimensions	430 x 305 mm
Max tray depth	95 mm (150)*
Max outside diameter of film roll	300 mm
Max width of film sealing	470 mm
Internal diameter film reel	70-76 mm
Vacuum pump	60 m <sup>3</sup> / h
Electrical supply	3 / N / PE 400V AC - 50 Hz **
Power consumption	Max 4,9 KW
Capacity	2-6 cycles /min.
Compressed air	6 bar - 7NI / c

### Number and max. tray dimensions processed per cycle

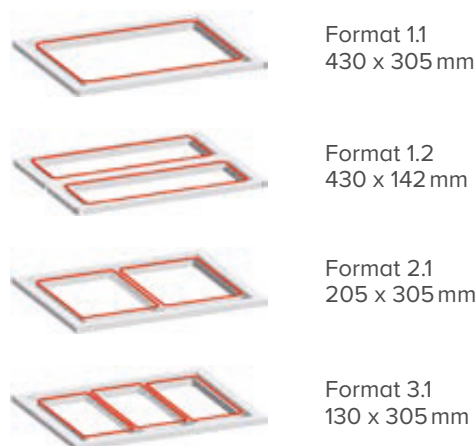

\*Optional

\*\*Different types of power supply available on request

# Berry 911VG Jumbo

## Semi automatic sealing machine

This machine was developed to process containers with a maximum size of 590 x 390 mm (one cavity) or 285 x 420 mm (two cavity) with vacuum and gas. The trays can contain products with volume up to 24,4 liter. This feature is well exploited in the fisheries sector. The operation is extremely simple and the control of the functions is via PLC. To the side of the machine there are rollers that allow the movement of the container which, after being packaged, is ejected from the machine.

### Standard

- Tray lifting system

### Options

- Photocell for printed film
- Filter for liquids and powders
- Side rollers

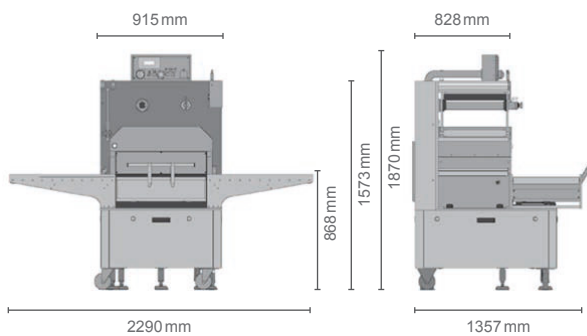

Technical data	911VG Jumbo
External dimensions	2290 x 1357 x 1870 mm
Weight	Approx 500 kg
Max tray dimensions	590 x 390 mm
Max tray depth	130 mm
Max outside diameter of film roll	250 mm
Max width of film sealing	460 mm
Internal diameter film reel	70-76 mm
Vacuum pump	100 m <sup>3</sup> / h
Electrical supply	3 / N / PE 400V AC - 50 Hz *
Power consumption	Max 4-9,5KW
Capacity	2-6 cycles /min.
Compressed air	6 bar - 25NI / c

Number and max. tray dimensions processed per cycle



Format 1.1  
590 x 390 mm



Format 1.2  
285 x 420 mm

\*Different types of power supply available on request



# Berry 1705VG

## Automatic sealing machine

For smaller-scale factories that are looking to grow, the 1705 is an automatic machine that won't clutter your production area. This compact unit offers the same level of versatility as its larger counterparts, with straight sealing, as well as vacuum and modified atmosphere packing (MAP) capabilities included as standard. The 1705 is electrically operated with no requirement for compressed air, resulting in low power usage that is incredibly economical. Working with a maximum tray size of 365 x 270 mm, you can also rest assured that this machine will accommodate almost all of your sealing needs.

### Options



- Photocell for printed film
- Filter for liquids and powders

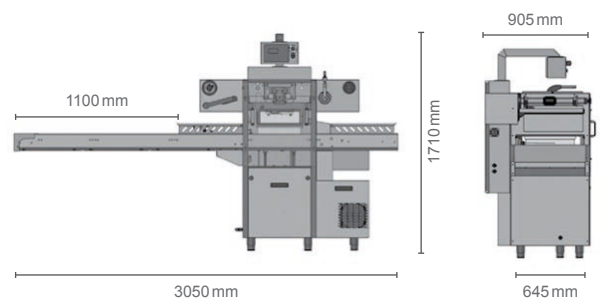

Technical data	1705
Machine height	1710 mm
Machine width	905 mm
Machine length	3050 mm
Machine weight	400 kg
In feed conveyor length	1810 mm
Length free loading area	1100 mm
No. of trays to load	3
Height free loading area	From 880 up to 910 mm
Tray Out-feed conveyor	Standard
Machine main movements	Electrical
Microprocessor control	PLC
Control panel	Touch screen
Electrical supply	3 /N/PE 400V AC 50 Hz
Electrical power	8 Kw /15,5A
Compressed air	0 NI /c.
Overall construction	Stainless-Steel



### Number and max. tray dimensions processed per cycle

	Format 1.1 270 x 365 mm Standard depth 100 mm
	Format 2.1 270 x 180 mm Standard depth 100 mm
	Format 3.1 270 x 113 mm Standard depth 100 mm

### Tooling

Sealing plate	Teflon Coated
Film cutting	Cutting unit device according tray profile

### Machine system

Only sealing	Up to 10 cycles/min. *
MAP process	60 m <sup>3</sup> /h vacuum pump - 4-8 cycles/min.

\*Cycle speed depending on: material quality of tray and film web, tray size, product to pack and general machine configuration

# Berry 1951VG

## Automatic sealing machine

The 1951 is a hardworking machine that is built to meet and exceed the expectations of even the most demanding production setups. As well as offering straight sealing, along with vacuum and modified atmosphere packing (MAP), this model can also be built to include skin and pro-skin packing capabilities upon request. The loading area can be increased to a maximum of four meters and it is able to integrate seamlessly with auxiliary equipment, offering a unique level of flexibility that adapts with the needs of your business.

### Options

- Photocell for printed film
- Filter for liquids and powders
- Pusher rods for special trays
- Indexing unit for infeed
- Tray converger
- Tray denester
- Dosing equipment
- Vibrating units

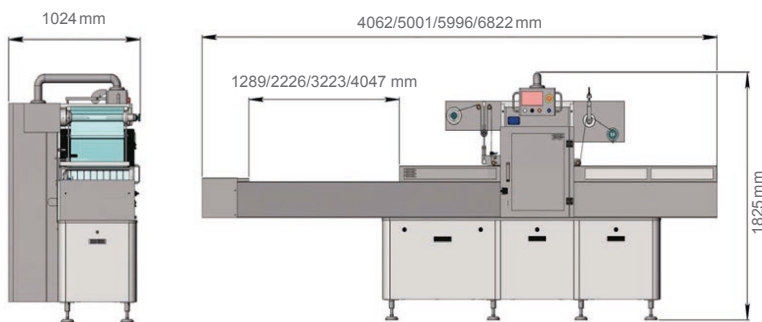

### Number and max. tray dimensions processed per cycle

#### Chamber Alt. 1 (1751)



Format 1.1  
360 x 380 mm  
Depth 130 mm



Format 2.1  
380 x 173 mm  
Depth 130 mm



Format 3.1  
380 x 108 mm  
Depth 130 mm

#### Chamber Alt. 2 (1951)



Format 1.1  
350 x 390 mm  
Depth 130 mm



Format 2.1  
350 x 227 mm  
Depth 130 mm



Format 3.1  
350 x 145 mm  
Depth 130 mm



Format 4.1  
350 x 104 mm  
Depth 130 mm

# Berry 1951VG

## Automatic sealing machine

Technical data	1951			
Max machine height	1825 mm			
Machine width	1024 mm			
Machine length	4062 mm	5001 mm	5996 mm	6822 mm
Free loading area for tray	1 m	2 m	3 m	4 m
Free loading positions	2	4	6	8
Tray index	457 mm			
Height of loading conveyor	915-960 mm			
Tray out-feed with motorized conveyor	Standard			
Die set in a single vacuum chamber	Standard			
Chamber movement	Electro-mechanical Servodrive			
Machine weight excluding vacuum pump	Approx. 1000 kg*			
Max width of top web	520 mm			
Max diameter of web roll	250 mm			
Film reel, inside diameter	76 mm			
Vacuum pump	100 - 200 - 300 m <sup>3</sup> / h			
Electrical supply	3 / N / PE AC 400V 50 Hz			
Power consumption	Min 4 Kw - Max 11 Kw			
Compressed air	6,8 NI / c.			
Machine cycles	** 6 - 15 for minute			

\*Depending on the machine equipment

\*\*With evacuation and gas flushing from 6 up to 10 cycles per minute - only sealing upto 15 cycles minute.

### Optional machine accessories

Photocell for printed film	✓
Liquid filter and powder	✓
Support for film printing device	✓
Special carrier rods for tray	✓

### Equipment

Conveyer conveying in 1 lane	✓
Tray de-nester	✓
Dosing units	✓

### Equipment

Different electrical supply	✓
Control and link to external equipment	✓
Connection for centralized vacuum system	✓

### Tool options

Easy-open tab	✓
Film webcut inside outline of the tray	✓
Die set in stainless steel	✓
Pre-cutting for tray multi-compartments	✓

# Berry 1752 & 1952VG

## Automatic sealing machine

Larger organisations rely on their machines to deliver fast results and with their twin tooling chambers, the 1752 and the 1952 offer production speeds that will easily keep up with demand. These machines can be built to incorporate skin packing abilities upon the request of our customers, alongside their standard specifications of vacuum/modified atmosphere packing (MAP) and straight sealing. Longer infeeds and effortless integration with auxiliary equipment make these models difficult to beat - both in terms of efficiency and quality. The 1752 and 1952 are performance-centric and designed to maximise the output of large-scale production companies.

### Options

- Photocell for printed film
- Filter for liquids and powders
- Pusher rods for special trays
- Indexing unit for infeed
- Tray converger
- Tray denester
- Dosing equipment
- Vibrating units

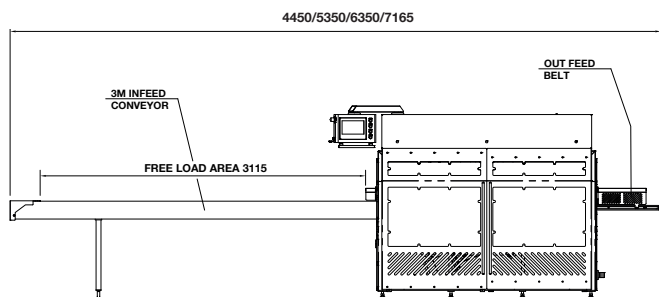

Number and max. tray dimensions processed per cycle

#### Separated knives 1752

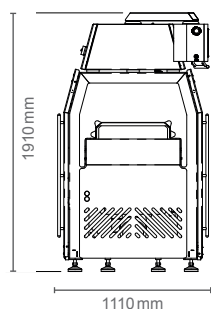

Format 1.1  
268 x 360 mm  
Depth 130 mm



Format 2.2  
268 x 173 mm  
Depth 130 mm



Format 3.2  
268 x 108 mm  
Depth 130 mm

#### 1952

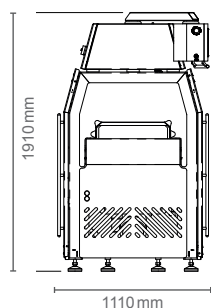

Format 1.1  
390 x 590 mm  
Depth 130 mm



Format 1.2  
268 x 390 mm  
Depth 130 mm



Format 2.2  
270 x 230 mm  
Depth 130 mm

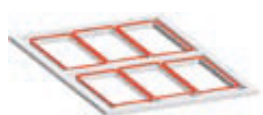

Format 3.2  
270 x 145 mm  
Depth 130 mm

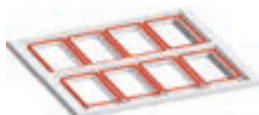

Format 4.2  
270 x 105 mm  
Depth 130 mm

# Berry 1752 & 1952VG

## Automatic sealing machine

Technical data	1752	1952		
Max machine height	1910			
Machine width	1110			
Machine length	4450 mm	5350 mm	6350 mm	7165 mm
Free loading area for tray	1 m	2 m	3 m	4 m
Free loading positions	3	6	9	12
Tray index	317 mm			
Height of loading conveyor	915-960 mm			
Tray out-feed with motorized conveyor	Standard			
Die set in a double vacuum chamber	Standard			
Double chamber movement	Electro-Mechanical Servodrive			
Machine weight excluding vacuum pump	Approx. 1.200 Kg*			
Max width of top web	520 mm			
Max diameter of web roll	250 mm			
Diameter of web roll mandrel	76 mm			
Vacuum pump available	100 - 200 - 300 m <sup>3</sup> / h			
Electrical supply	3 / N / PE AC 400 V50 Hz			
Power consumption	Min 25A 15 Kw - Max 55A 32 Kw			
Compressed air	7,6 NI / c		13,6 NI / c	
Machine cycles	** 8-15 for minute			

\*Depending on the machine equipment

\*\*With evacuation and gas flushing from 6 up to 10 cycles per minute - only sealing upto 15 cycles minute.

Optional machine accessories	1705	1951	1752/1952
Photocell for printed film	✓	✓	✓
Liquid filter and powder	✓	✓	✓
Special carrier rods for tray	✓	✓	✓

Equipment	1705	1951	1752/1952
Conveyer conveying in 1 lane	-	✓	✓
Tray de-nester	✓*	✓	✓
Dosing units	-	✓	✓

Equipment	1705	1951	1752/1952
Different electrical supply	✓	✓	✓
Control and link to external equipment	✓	✓	✓
Connection for centralized vacuum system	✓	✓	✓

Tool options	1705	1951	1752/1952
Easy-open tab	✓	✓	✓
Film webcut inside outline of the tray	-	✓	✓
Die set in stainless steel	✓	✓	✓

\*Stand alone de-nester







 +44 1256 844700

 +33 3 4464 4114

 +49 4191 9567 161

 +358 2 489 555

 +34 937 297 245

 **Berry** | Superfos  
Packaging Solutions

Stadionveien 15, P.O. Box 1514 Lundsiden, N-4688 Kristiansand, Norway  
+47 38 14 40 00 | SuperfosKristiansand@berryglobal.com | superfos.com